

Architectural Product Information

Specifications subject to change, for the latest up to date information, go to www.ChadwickDesigns.com. Data can be downloaded in various formats. For technical questions and information, call 1-800-925-0005

Specification Sheet for the C-01 Corner Sconce 06/27/03

Front View

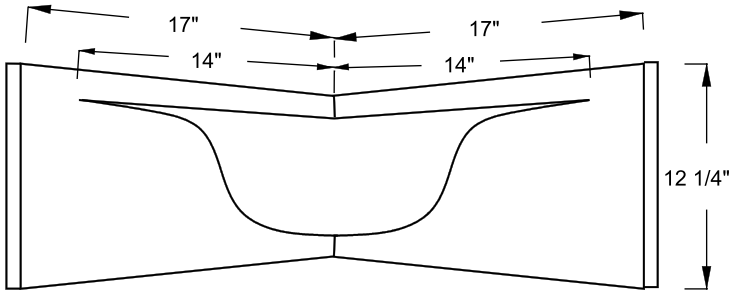

Location of J Box

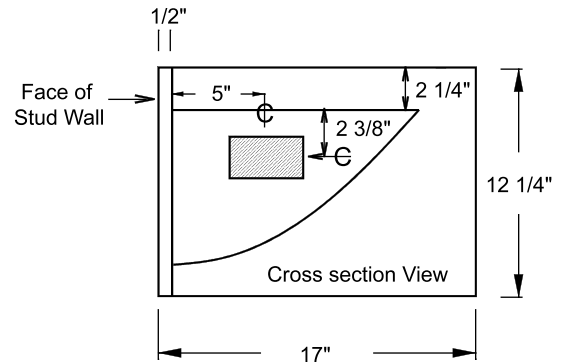

Top View

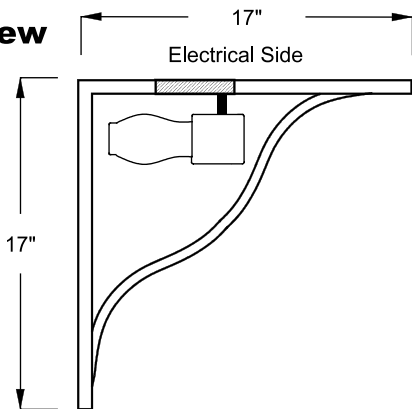

Handy Box Application

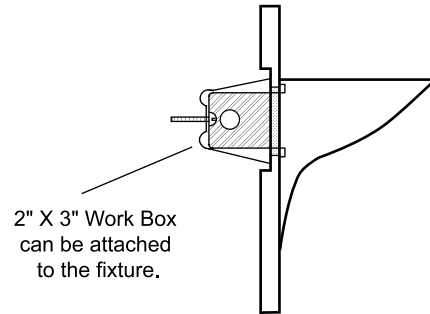

Cross Section of Cut in Box Attached to Fixture

Nail on J-Box Application

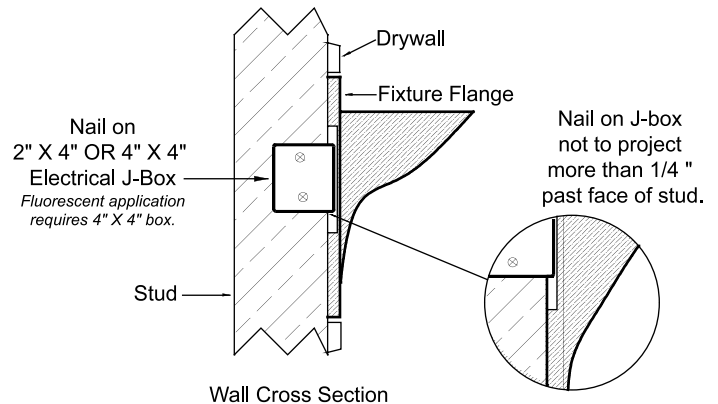

Wall Cross Section

Standard Lamping

Incandescent, Med. Base, A Type Bulb, 100 Watt, 120V

Lamping Options

Fluorescent: PL Sockets, GX23, 13 Watts

Custom Lamping Per Request

Fire and Product Data

Material: 5,000 psi Reinforced Plaster Mix

Flash Point: Non-Combustible

Melting Point: 1450 C Decomposes

Parts List

Plaster Fixture

Complete Light Assembly Kit

Heat Shield

Shims for 5/8" Rock Application

Fastening Screws

Installation Instructions and Specification Sheets